

dancook[®]

danish gastronomic design

Wonderfully simple



Hygge | PRODUCTS &
RECIPE BOOK

dancook[®]
danish gastronomic design

Wonderfully simple



Take a closer look



ALL EXTERNAL PARTS AGAINST RUST THROUGH

This is where form and function truly come together. Dancook believes high specification and elegant design in outdoor cooking can, and should, go hand-in-hand. Outdoor cooking has long been part of the time-honoured Danish tradition of enjoying meals cooked and shared in the beautiful outdoor settings of Denmark and is conducive to creating that feeling of hygge.

Don't be misled by the apparent simplicity of Dancook products such as few moving parts, no complicated features and ash buckets. It is often not until people actually experience cooking with Dancook that they appreciate this simplicity and they discover the wonders that lie beneath the products' elegant appearance.

What you will come to appreciate is that behind the elegant design there's a host of unique initiatives. Take the kettle range for instance... for easier cooking, this range is taller than normal so you don't need to bend over, and the air flow system pre-heats the incoming air to ensure more even and economical cooking. Cleaning is also easier due to the patented removable liner that doesn't need any fiddly levers for easy removal of grease and ash.

Dancook products are manufactured to last a lifetime with top-quality stainless steel and aluminium. Whether you want a full outdoor kitchen with a sink and granite work surfaces or something more mobile for the beach, it's worth getting to know Dancook by taking a closer look.

Discover your wonderfully simple.

Hygge

['Hoo-gah']

(Verb / Danish)

Hygge is a Danish word used when acknowledging a feeling or moment of cosiness and comfortable conviviality that embodies a feeling of contentment or well-being.

Some also refer to hygge as an art of creating intimacy, often with friends and family at home (your home). It is often described using terms such as happiness, security, familiarity, comfort, reassurance, kinship and simpleness.

Being aware of each and every good moment.

Keeping things simple.



Less is more

From a distance, Dancook barbecue and kitchen ranges cleverly disguise the technology that lays lies within. This is not a brand that likes to pump out its chest and boast its manhood. Instead, it seeks to prove its effectiveness through genuine and robust innovative features that are

cleverly disguised within its subtle design; features that are there to be discovered by those who appreciate great design, where every component has a reason for being. It's a sophisticated approach to outdoor cooking. This is the Dancook way to impress.



REDUCED FLARE UPS



MORE UNIFORM HEAT



UP TO 50% LESS FUEL CONSUMPTION



VERTICAL GRILLING



EASY CLEAN

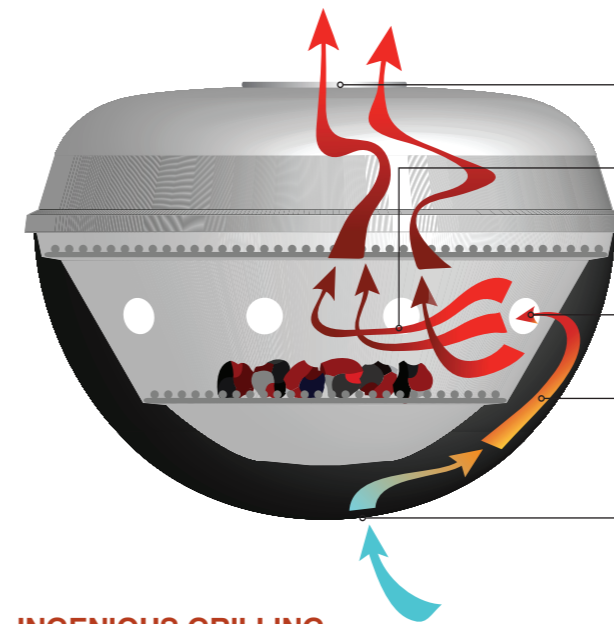

Heat can be regulated by adjusting vents in the lid.

This dual source of heat means:

- 50% less charcoal is required
- 200% increase in cooking time.

Vents in the internal wall allow the pre-heated air to combine with the heat from the charcoal.

The cool air is pre-heated as it travels around the inner kettle wall.

Vents in the kettle's underside draws in cool air.

INGENIOUS GRILLING

The use of a simple but clever air flow system improves the efficiency of burning charcoal by up to 50%. This means you can cook for longer, create less ash or re-use charcoal that

hasn't been burnt. This system also creates a more even heat distribution across the whole grill, so everything cooks at the same rate.

DISCARDING THE CONVENTIONAL



Kettle barbecues normally adopt two approaches to ash and grease removal; some simply allow the waste to fall into the bottom of the bowl which is neither hygienic or convenient, whilst some add a removable bucket underneath which isn't always easy to move and doesn't resolve the issue of grease build up over the moving parts.

Dancook has invented a system that simply provides a convenient and hygienic solution. Its patented removable liner allows quick and easy cleaning without any levers or rotating blades.

APPROACHING FROM A DIFFERENT ANGLE

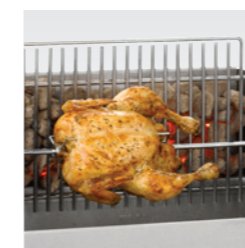

The majority of the Dancook box barbecue range offers four different grill levels for controllable cooking and reducing flare-ups. Also, through clever innovative design, the grill can also be vertically mounted at the back of the barbecue. This enables back-filling of the grill with charcoal to make spit roasting more controllable or allowing indirect grilling.

This method further reduces the risk of flare-ups by catching dripping meat juices in a foil tray which can then be used later for flavouring sauces.

A DIFFERENT DIMENSION



If you've experienced food sticking to the grill or the grill becoming thin and needing replacement after a short period, then try using a thicker diameter grill.

Dancook grills are made from 6mm chromium-plated steel that's built to last and distributes heat better than more flimsy grills - especially noticeable with heavier cuts of meat or fish.

SIMPLY BETTER BUILT

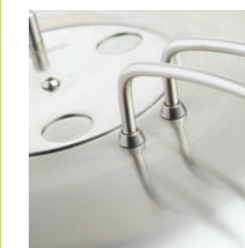

Cooking and eating outside is very therapeutic and good for the soul. You can relax in the knowledge that Dancook products are manufactured to last a lifetime with top-quality materials including stainless steel, aluminium and FSC certified saligna eucalyptus hardwood.



But that's only half the story. There are different grades of stainless steel and Dancook's stainless steel is a commercial kitchen 'non-magnetic' grade which will never rust. Dancook uses an aluminium coating called anthracite enamel which is the same material used to protect oven baking trays from sticking, scratching and cutting marks. This also makes the Dancook box barbecues very easy to clean.

Designed for the love for cooking



DENMARK HAS SOME OF THE MOST BEAUTIFUL SCENERY THAT CONSTANTLY BECKONS YOU TO SIT OUTSIDE IN FRONT OF A WARMING FIRE WITH THE GOOD COMPANY OF FRIENDS AND FAMILY.



It's little wonder that the Danes have a long tradition for cooking outdoors. Founded on this Danish tradition, Dancook always aims to create well designed, simple but innovative cookware for the best possible cooking results.

Since 1992, Dancook has been developing functional but elegant barbecues that are built to last. To this day, Dancook stays true to its core values by manufacturing all these unique products in solid materials - while constantly striving to perfect its original ideas in close co-operation with its customers.

Dancook proudly manufactures barbecues in Laurbjerg, Denmark.



dancook[®]
danish gastronomic design

BARBECUE RANGES:

- > Kitchen
- > Kettles
- > Boxes
- > Mobile

Dancook Kitchen

DESIGN YOUR OWN OUTDOOR KITCHEN

The Dancook Kitchen is the ultimate barbecue and a kitchen at the same time. Available with everything except the kitchen sink, this modular system will in fact allow you the option of fitting a sink too should you require one!

Start with the kitchen frame (art.no.170000) and then choose what to place in the four square slots. You may decide to fill one slot with a 58cm kettle in your first frame then buy another frame purely filled with work surfaces – the choice is yours!

As a tip, the large tabletop in granite (62x62cm) is ideal for preparing dinner before cooking.

All modules are manufactured in weatherproof materials – granite, saligna eucalyptus hardwood, anodised aluminium and commercial grade stainless steel.

Compatible with Dancook's innovative 58cm kettle with 54cm grill.



Table - granite
Art. nr. 170 001

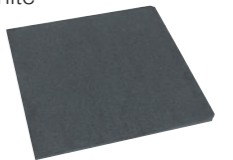

Table - Saligna FSC
Art. nr. 170 003



Table - stainless steel
Art. nr. 170 005

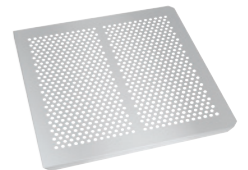

Table - stainless steel
Art. nr. 170 004



Grid - stainless steel
Art. nr. 170 006



Dancook Kettles

DANCOOK 1500 / DANCOOK 1501

Form and function reach new levels with these two impressive models that offer an extended prep and plate work surface straight from the grill, with large storage shelf below.

This simple and stylish design is underlined by the choice of lower shelf materials – either stainless steel or saligna eucalyptus hardwood. Commercial grade stainless steel and anodised aluminium is used throughout. Both models come with Dancook's innovative 58cm kettle with 54cm grill.



Dancook 1500

Art. nr. 109 600

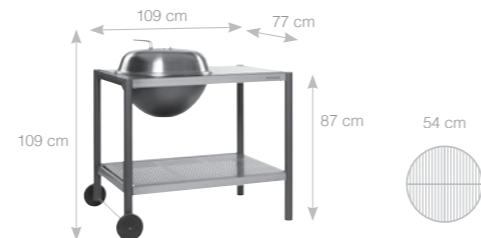

Dancook 1501

Art. nr. 109 601

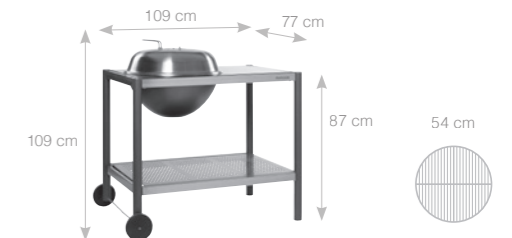

Dancook Kettles

DANCOOK 1600 / DANCOOK 1400 / DANCOOK 1000

A Dancook kettle barbecue is best characterised by its simple design and numerous unique details. The materials used are commercial grade stainless steel and aluminium. The 6mm grid and the various built in details guarantee optimal cooking results every time. In addition, Dancook supplies an extensive range of accessories to accompany the Dancook kettle barbecue.

The unique and patented liner in a Dancook kettle barbecue collects grease and ashes, making it extremely easy to keep clean. Also, because the combustion air is pre-heated, the cooking effect is increased by 50% and reduces the use of briquettes.

DANCOOK 1800 / DANCOOK 1900

Setting the standard for kettle barbecues, these magnificent models are manufactured with a one piece anodised aluminium frame which delivers optimal stability and cooking ergonomics.

The eye-catching structure uses gravity alone to secure the barbecue kettle once it is dropped into its ring of commercial grade stainless steel. The barbecue can be further enhanced with a solid aluminium side table. Both models come with Dancook's innovative 58cm kettle with 54cm grill.



Dancook 1800

Art. nr. 109 502

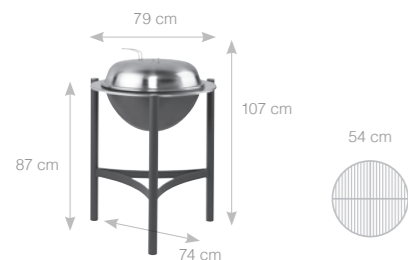

Dancook 1900

Art. nr. 109 500

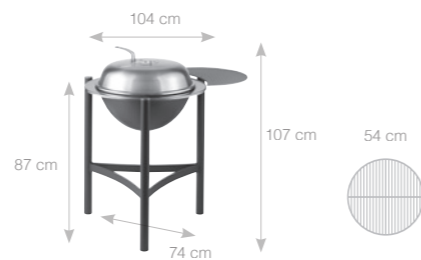

Dancook 1400

Art. nr. 109 001



Dancook 1000

Art. nr. 109 000



Dancook 1600

Art. nr. 109 004



Dancook Boxes

DANCOOK 5000

Double barbecue with 2 sidetables made of FSC certified saligna eucalyptus hardwood. Anthracite enamel with non-stick - maintenance friendly surface. Heat resistant, aluminium coated tray. Two sturdy, 6mm chromium plated grids, adjustable in four positions.

DANCOOK 5600

Aroma increasing lid. 2 sidetables in FSC certified saligna eucalyptus hardwood. Anthracite enamel with non-stick - maintenance friendly surface. Heat resistant, aluminium coated tray. Sturdy, 6 mm chromium plated grid, adjustable in four positions. Vertical barbecuing possible using spit and electric motor.

DANCOOK 5100

Anthracite enamel with non-stick - maintenance friendly surface. Heat resistant, aluminium coated tray. Sturdy, 6 mm chromium plated grid, adjustable in four positions. Vertical barbecuing possible using spit and electric motor.

DANCOOK 5200/5300

2 sidetables made of FSC certified saligna eucalyptus hardwood. Anthracite enamel with non-stick - maintenance friendly surface. Heat resistant, aluminium coated tray. Sturdy, 6mm chromium plated grid, adjustable in four positions. Vertical barbecuing possible using spit and electric motor.



VERTICAL BARBECUING



Dancook 5000

Art. nr. 102 623

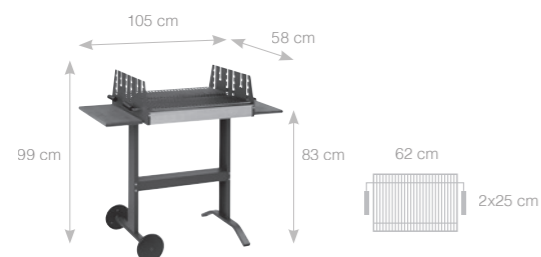

Dancook 5600

Art. nr. 104 612

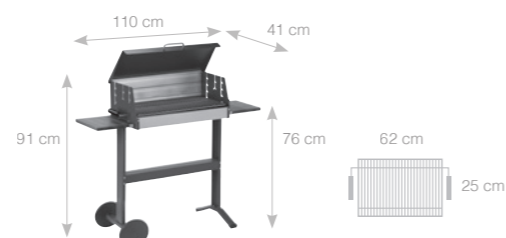

Dancook 5100

Art. nr. 104 501



Dancook 5200

Art. nr. 104 511



Dancook 5300

Art. nr. 104 611

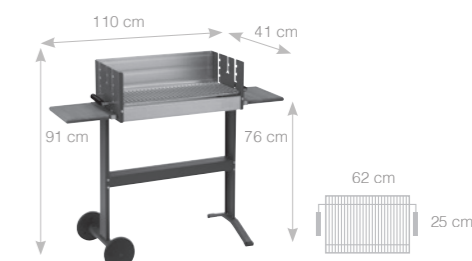

Dancook Boxes



Dancook 7500

Art. nr. 101 626

Dancook 7300

Art. nr. 101 507

7300/7500

2 sidetables made of FSC certified hard wood. Anthracite enamel with non-stick - maintenance friendly surface. Heat resistant, aluminium coated tray. Sturdy, 6 mm chromium plated grid, adjustable in four positions. Vertical barbecuing possible using spit and electric motor.

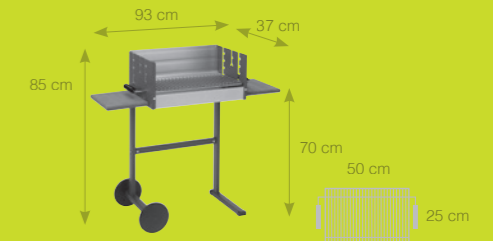
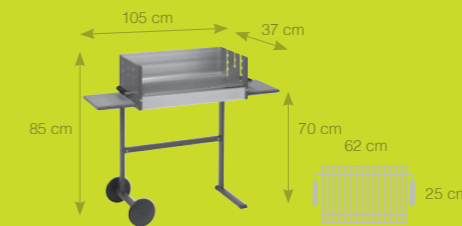

Dancook 7100

Art. nr. 101 501

Dancook 7000

Art. nr. 101 422

DANCOOK 7000/7100

Anthracite enamel with non-stick - maintenance friendly surface. Heat resistant, aluminium coated tray. Sturdy, 6 mm chromium plated grid, adjustable in four positions. Vertical barbecuing possible using spit and electric motor.

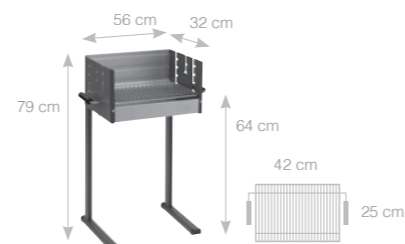
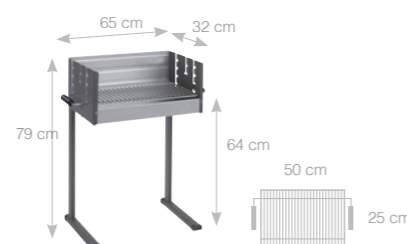

Dancook 7400

Art. nr. 101 621

Dancook 7200

Art. nr. 101 502

DANCOOK 7200/7400

Anthracite enamel with non-stick - maintenance friendly surface. Heat resistant, aluminium coated tray. Sturdy, 6 mm chromium plated grid, adjustable in four positions. Vertical barbecuing possible using spit and electric motor.

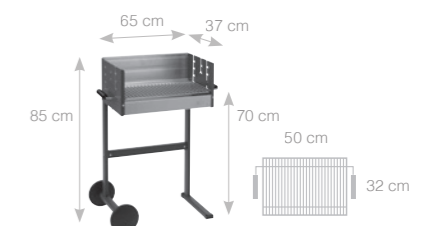
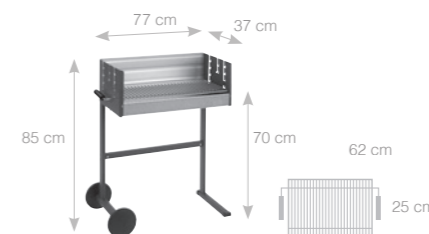



Mobile Barbecues

DANCOOK 1300/8100 MOBILE BARBECUES

The mobile kettle barbecue from Dancook is extremely suitable for outdoor living, camping, the beach or balcony. The use is only limited by your imagination. The unique and patented liner secures ashes and embers inside and offers all the benefits of its bigger kettle cousins.



Dancook 1300

Art. nr. 109 008



Dancook 8100

Art. nr. 106 421

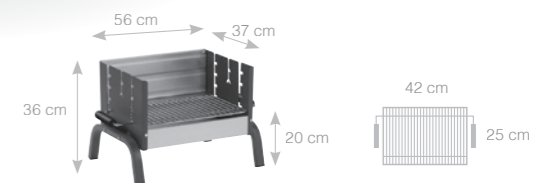



dancook[®]
danish gastronomic design

> Firepits

Dancook Firepits

DANCOOK 9000

The Firepit from Dancook will become the natural gathering point for your whole family. Enjoy having a barbecue with fireside cosiness all at the same time - compatible with either wood or charcoal.

Due to its height and because the edges of the Firepit do not get warm it has an added benefit of being safe for children. The Firepit is made from commercial grade stainless steel and anodised aluminium, while the cooking grill is made from 6mm chromium-plated steel, which makes for a better distribution of the heat. It's a cosier alternative to a terrace heater and is easy to move around. Create your hygge family moments!



Dancook 9000

Art. nr. 110 000

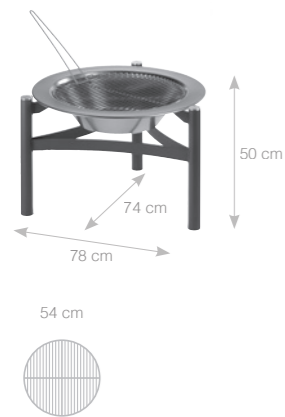

Dancook 9400

Art.nr. 110 400

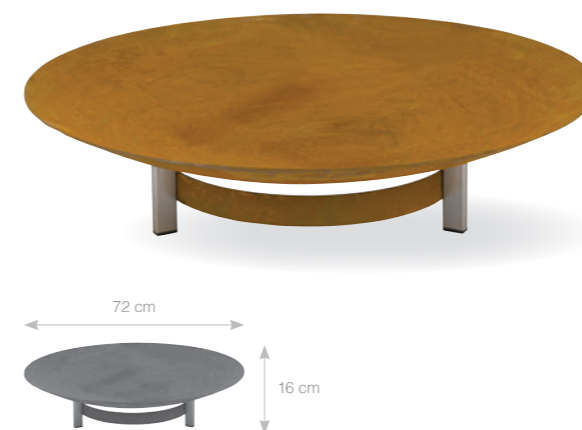

FIREPIT AND GRILL

Dancook 9400 + 9500

Dancook 9500

Art.nr. 110 500

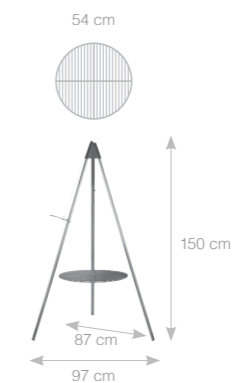



dancook[®]
danish gastronomic design

ACCESSORIES:

- > BBQ
- > Firepits

Accessories

Tong

Art. nr. 130 101



3 pcs. barbecue set
- stainless steel

Art. nr. 130 154



Barbecue mitten

Art. nr. 120 153



Hooks - stainless steel (x 3)

Art. nr. 120 017



Warming rack - stainless steel
For 50 & 58 cm kettlebarbecues

Art. nr. 120 019

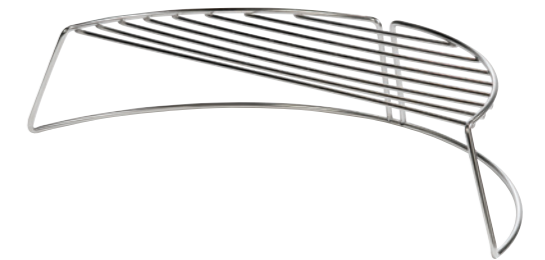

Grill brush

Art. nr. 120 148 - 45 cm

Art. nr. 120 149 - 30 cm



Grill brush

Art. nr. 120 152



Charcoal divider - stainless steel

Art. nr. 120 015

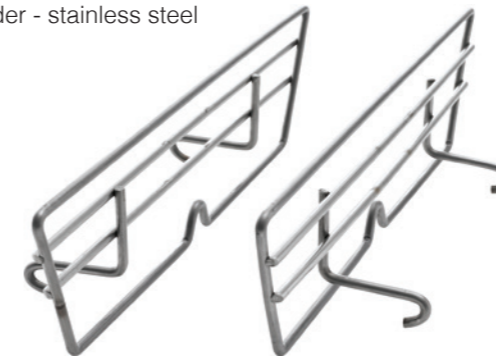

Handle
- stainless steel

Art. nr. 120 016



Barbecue broiler

Art. nr. 130 116



Meat forks

Art. nr. 130 107



Charcoal briquet holder

Art. nr. 120 155

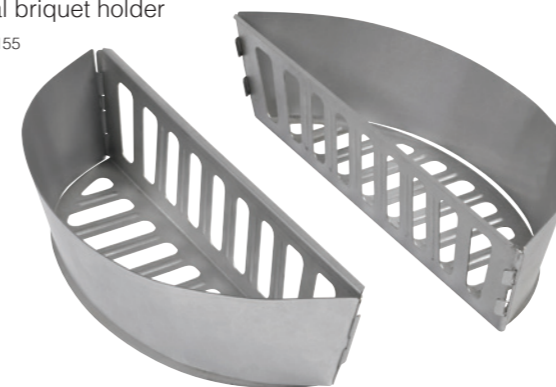

Double prong skewers
(x 8)

Art. nr. 120 142



Barbecue spit

Art. nr. 130 105 - 42 & 50 cm

Art. nr. 130 106 - 62 cm



Barbecue motor
1,5 V

Art. nr. 130 110



Barbecue motor
230 V

Art. nr. 130 111



Grid
Dancook 1600, 1300
Art. nr. 120 122

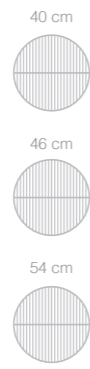
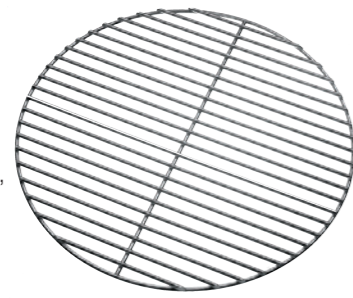

Dancook 1000
Art. nr. 120 013

Dancook 1400, 1800, 1900,
1500, 1501, Kitchen, 9000
Art. nr. 120 014

Digital thermometer
Art. nr. 120 147



Dancook 1800
Art. nr. 130 144



Dancook 1400
Art. nr. 130 143

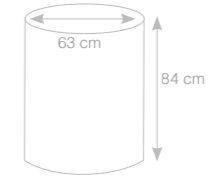

Dancook 1000, 1600
Art. nr. 130 139

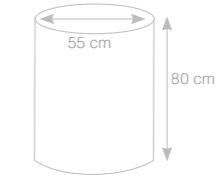

Pizza plate
Diameter 36 cm
Art. nr. 120 123



Cleaning tray
- stainless steel
Art. nr. 120 124



Poultry roaster
Art. nr. 120 140



Rib rack
Art. nr. 120 141



Roast holder
Art. nr. 120 143



Roast holder
Art. nr. 120 144

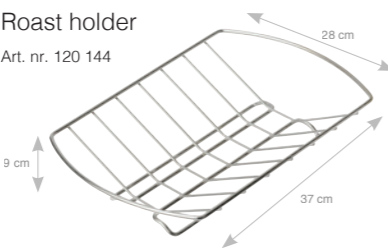

Dancook 1500, 1900, 5000
Art. nr. 130 138



Dancook 5200, 5300, 5600, 7300, 7400 & 7500
Art. nr. 130 125



Small drip pans
(x 10)
Art. nr. 120 145
15 x 21 cm



Large drip pans
(x 10)
Art. nr. 120 146
23 x 33 cm



Cook pan
- stainless steel
Art. nr. 120 154



Kitchen Cover
Art. nr. 170 200



Dancook 5100, 7000, 7100 & 7200
Art. nr. 130 124



Barbecue starter

· 2,5 kg
Art. nr. 120 000



Electric barbecue starter

Art. nr. 130 122

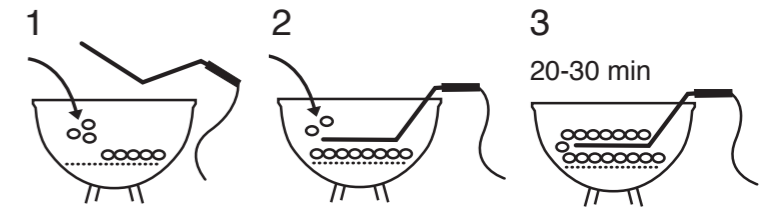

Smoking powder

Art. nr. 120 002



BOX BARBECUE ACCESSORIES

Grid

Art. nr. 120 004 - 40 x 60 cm

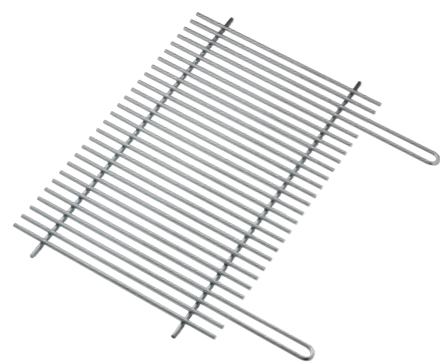
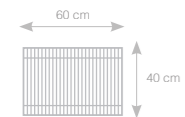

Universal shelf
For 50 and 62 cm
box barbecues

Art. nr. 130 120



FIREPIT ACCESSORIES

Revolving holder
- stainless steel

Ø 53 cm
Art. nr. 110 100



Grid

Dancook 7000, 8100

Art. nr. 120 010 - 25 x 42 cm

Dancook 7100, 7200, 7300, 5100, 5200

Art. nr. 120 011 - 25 x 50 cm

Dancook 7400, 7500, 5300, 5600, 5000

Art. nr. 120 012 - 25 x 62 cm



Charcoal tray

Dancook 7000, 8100

Art. nr. 120 130 - 25 x 39 cm

Dancook 7100, 7200, 7300, 5100, 5200

Art. nr. 120 131 - 25 x 47 cm

Dancook 7400, 7500, 5300, 5600, 5000

Art. nr. 120 132 - 25 x 60 cm



Spark guard

Art. nr. 110 104



Lid - stainless steel

Ø 72 cm
Art. nr. 110 102



Cover
Art. nr. 110 103

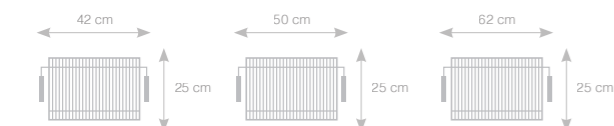

Spit
- stainless steel

79 cm
Art. nr. 120 018



Side table
- aluminium

Art. nr. 120 121

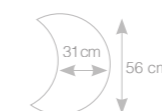

Barbecue pan
- stainless steel

Art. nr. 110 101



Recipes

FOR YOUR OWN HYGGE MOMENTS

IF YOU APPROACH YOUR COOKING LIKE DANCOOK APPROACHES ITS PRODUCT DESIGN, THEN YOU'LL CERTAINLY ENHANCE THOSE SPECIAL MOMENTS WITH FRIENDS AND FAMILY.

THE DANCOOK APPROACH IS TO THINK THINGS THROUGH AND KEEP THINGS SIMPLE. WHETHER YOU'RE A BIT OF AN OUTDOOR CHEF OR A NEWCOMER TO OUTDOOR COOKING WITH SOME BASIC COOKERY SKILLS, YOU CAN RELY UPON YOUR DANCOOK BARBECUE TO COOK YOUR RECIPES TO PERFECTION.

SIMPLE TIPS:

PRE-PLAN YOUR COOKING PROCEDURE.

Mentally rehearse how the food will be cooked. How many people, what types of food and how many dishes will dictate the process that you need to adopt.

Are you cooking over indirect heat (similar to an oven) or directly (similar to a grill)? If you're cooking directly over heat maybe you can leave a cooler area to one side for resting the food?

Whole chickens and joints of meat are better cooked indirectly and more slowly, especially with lamb, whilst kebabs and burgers gain more flavour if allowed to drip meat juices directly over the coals. These are all considerations that can make a difference to your success.

BUY THE BEST

If you've bought a Dancook barbecue, then you're probably not in need of convincing that it's worth buying the best you can afford. If selecting your meat from the butcher, take advice on your selection rather than taking a gamble. Butchers can provide a wealth of information such as what's the best beef to put into a burger? - This is just one example of the level of detail that can help make your occasion extraordinary.

PREPARATION IS EVERYTHING

Make sure you have everything prepared in advance. Avoid the stress of hunting or preparing ingredients whilst you're cooking food or this could be a recipe for disaster.

Allow your steaks to briefly reach room temperature and then rub them with a sprinkle of sea salt before cooking - the flavour will come to life.

If you're cooking over indirect heat, place a foil tray under the meat. This will save you a cleaning job and the juices can be reduced for an amazingly tasty sauce.

Prepare a warming oven indoors or use a second barbecue on low heat to cater for large volumes or multiple courses. You don't want food going cold.

LIGHT UP EARLY

For a more even temperature, we recommend charcoal briquettes and to use the Dancook barbecue starter. This speeds up the lighting process by drawing air from underneath - just as a chimney does. Then you'll find that 20 minutes should be sufficient time for the briquettes to all turn grey. By rotating the double handles on the Dancook barbecue starter you can then safely tip the charcoal away from you into the barbecue.

Use firelighters that have been made for barbecues as they're less harmful and less likely to contaminate the flavour of the food you're cooking.

GET COOKING

Spray a little oil on your food, especially if you're cooking fish or delicate dishes over direct heat to stop things sticking.

Use a timer - friends and family can be a distraction and when they arrive you'll not want to miss out on the latest news and conversation.

Be ambitious - you can cook practically anything on a Dancook barbecue with the right accessories so don't be put off if recipes appear to have been created for the oven or hob.

KEEP YOUR EYE ON THE TEMPERATURE

Over time you will be able to judge the temperature of your barbecue but if in doubt use a temperate gauge before cooking and a meat thermometer before serving.

Use the rule of thumb for steaks (bearing in mind just 2-3 minutes cooking time separate these): Rare 50°C, Medium 60°C, well done 70°C. Use your senses - sight, smell and especially sound can tell you everything about your steak.



Marinated Veal

WITH ROMAINE SALAD AND LEMON CREAM



difficulty
8/10



preparation
30 mins



cooking
12 mins



people
4

INGREDIENTS

- > 2kg veal fillet
- > 1 teaspoon salt
- > 1 teaspoon black pepper
- > 1 teaspoon smoked paprika
- > 2 teaspoons sugar
- > 1 teaspoon garlic salt
- > 1 teaspoon cumin
- > 6 tablespoons grapeseed oil
- > 2 cups whipping cream
- > 1 lemon
- > 24 spring onions
- > 2 heads romaine lettuce, outer leaves removed
- > Additional salt and pepper

METHOD

1. Slice the veal as thinly as possible and lay the slices in a large, flat-bottomed glass dish.
2. In a small bowl, mix 1 teaspoon salt, pepper, smoked paprika, 1 teaspoon sugar, garlic salt and cumin with the oil and pour the marinade over the thinly-sliced veal.
3. In a small bowl, mix the whipping cream, juice from the lemon, 1 teaspoon sugar and a pinch of salt and pepper without whipping it. Let the dressing stand for approximately 20 minutes or until it thickens.
4. Place the washed spring onions on a very hot grill until they brown and give off a slightly "burnt" aroma.
5. Remove from the grill and set aside.
6. Add the veal and flash grill them for approximately 30 seconds on each side.
7. Top romaine leaves with the dressing and serve with the veal and spring onions.



Herbed Whole Fish

WITH POTATO-RADISH SALAD



difficulty
6/10



preparation
20 mins



cooking
30 mins



people
4

INGREDIENTS

- > 4 whole sea bream (other oily fish, such as mackerel, can be substituted)
- > 2 bunches fresh parsley
- > 2 bunches fresh dill
- > 1 bunch fresh thyme
- > 1 bunch fresh coriander
- > 1 bunch radishes
- > 1 kg new potatoes
- > 1 stick of salted butter
- > 2 lemons
- > 2 tablespoons of coarse mustard
- > 6 tablespoons olive oil
- > Salt and black pepper

METHOD

1. Season the cleaned fish with salt and black pepper and refrigerate for one hour or more.
2. Boil the potatoes in well-salted water until just tender and let cool.
3. Place one bunch of parsley, one bunch of dill, thyme and coriander into a large bowl and cover with water.
4. Wash the radishes and cut them into fourths. Cut the potatoes into the same sized pieces and mix the radishes and potatoes together in a large bowl.
5. Pick and chop the last bunch of dill and mix with the oil and mustard in a small bowl. Season the dressing with salt, pepper and the juice from one lemon. Pour the dressing over the radishes and potatoes and mix into the salad.
6. Melt butter in a small pan on a stovetop until it begins to brown. Pour the browned butter through a sieve into a small bowl and set aside.
7. Add the wet, but not dripping, herbs to a hot grill. Place the fish on the herbs and immediately close the lid.
8. Let the fish cook approximately 12 minutes or until the meat feels loose under the skin and liquid from the fish is transparent.
9. Transfer the fish from the grill to a plate, top with the browned butter and serve with the potato-radish salad and lemon wedges.



Whole Chicken

WITH RAW CAULIFLOWER SALAD



difficulty
3/10



preparation
15 mins



cooking
1 hr
30 mins



people
4

INGREDIENTS

- > 1 whole organic chicken approx 1.75kg
- > 2 organic lemons
- > 1 bunch fresh thyme
- > 1 bunch fresh rosemary
- > 1 bunch fresh parsley
- > 1 head of cauliflower
- > 6 tablespoons olive oil
- > Pinch of cumin
- > Salt and pepper

METHOD

1. Clean the chicken thoroughly and season it inside and out with the rosemary, thyme and the skins of the lemon (use only the yellow part of the skins as the whites are bitter). Save the lemons for the salad.
2. Place the chicken in a greased, oven-safe dish.
3. Grill the chicken with the lid on for approximately 1 hour 30 minutes at 200°. The chicken is done when you can easily separate the thigh from the body.
4. Cauliflower Salad: Chop the flowers of the cauliflower as fine as possible (it should resemble couscous). Discard stems.
5. Mix the cauliflower with the juice from the lemons, olive oil, salt, pepper and a pinch of cumin. Allow the salad to rest 30 minutes before serving.
6. Best served with fresh-baked bread and cold slabs of butter.



Pork Tenderloin

WITH THYME AND ASPARAGUS



difficulty
3/10



preparation
1 hr



cooking
20 mins



people
4-6

INGREDIENTS

- > 2 pieces pork tenderloin approx 2kg
- > 2 tablespoons fresh thyme
- > 20 stalks asparagus
- > 3 tablespoons grapeseed oil
- > 1 lemon
- > 2 tablespoons sugar
- > Salt and pepper

METHOD

1. Remove tendons and fat from the tenderloin and season it with plenty of salt, pepper and thyme. Wrap the seasoned tenderloin in plastic wrap and let it rest in the refrigerator for one hour.
2. Clean the asparagus thoroughly and season with salt, pepper and sugar.
3. Place them in a shallow dish with the juice from the lemon and oil.
4. Remove the wrap and grill the marinated tenderloin over high heat for 5 to 8 minutes on each side or until it reaches a safe internal temperature of 145°. Remove the tenderloin from the grill and allow it to rest for 5 to 10 minutes.
5. While the tenderloin is resting, add the asparagus to the grill, cooking just long enough for them to turn a bright green while remaining tender-crisp.
6. To serve, lay 5 stalks of asparagus on each plate and top with sliced tenderloin.
7. Best served with a simple green salad and warm bread.



Grilled Vegetable Salad



difficulty
5/10



preparation
10 mins



cooking
15 mins



people
3

INGREDIENTS

- > 2 aubergines
- > 2 yellow squash
- > 2 green squash
- > 2 medium white onions
- > 1 stalk celery
- > 4 medium tomatoes
- > ½ cup olive oil
- > 250g raw baby spinach
- > 2 sprigs rosemary
- > 2 tablespoons fresh lemon juice
- > 1 teaspoon paprika
- > Salt and black pepper

METHOD

1. Slice the aubergines, yellow squash and green squash into one-inch pieces. Cut the onion into one-inch wedges. Transfer the vegetables to a large bowl and salt lightly. Let the salted vegetables rest for approximately 20 minutes.
2. Cut the celery cross-wise into thin slices and cut the tomatoes into 12mm chunks.
3. Rinse the salted vegetables and dry them with a clean dishtowel. Return them to the bowl and mix in the olive oil.
4. Arrange the oiled vegetables on a very hot grill. Once they have browned and become slightly soft, transfer them to a large bowl and mix them with spinach, tomato, celery, rosemary, lemon juice, paprika and black pepper.
5. Best served with fresh-baked bread.



Brown Sugar Peaches

IN BUTTER-RUM SAUCE



difficulty
5/10



preparation
15 mins



cooking
40 mins



people
4

INGREDIENTS

- > 4 whole peaches
- > 450g brown sugar
- > 225g dark rum
- > 1 vanilla bean cut in half lengthwise
- > 2 sticks unsalted butter
- > Pinch of sea salt
- > 1 cup crème fraiche

METHOD

1. Place an aluminum tray onto a warm grill.
2. Slice the peaches in half and remove the pits. Lay peaches sliced-side down in the warm tray and cook until the peaches turn a bright colour, or approximately 2 to 5 minutes.
3. Pour the brown sugar and rum over the peaches and add the vanilla bean. (Pour the rum carefully and take care not to splash or spill as the alcohol will catch fire!) Add the butter to the pan.
4. Let the peaches cook an additional 20 minutes or until the peaches are soft.
5. Remove from heat and serve with a dollop of crème fraiche.

Recipe Notes

A large area of horizontal dotted lines on a light wood background, intended for writing recipe notes.



dancook[®]
danish gastronomic design



Wonderfully simple

Dancook[®] Barbecues come with a **15 YEAR WARRANTY**

🔍 Search 'dancook' to discover the wonderfully simple!

DANCOOK KITCHEN Art. nr. 170 100



 **MADE IN DENMARK**

dancook[®]
danish gastronomic design

Wonderfully simple

🔍 Search 'dancook' to discover the wonderfully simple!